

DENON

STEREO CD PLAYER

DCD-1500

OPERATING INSTRUCTIONS

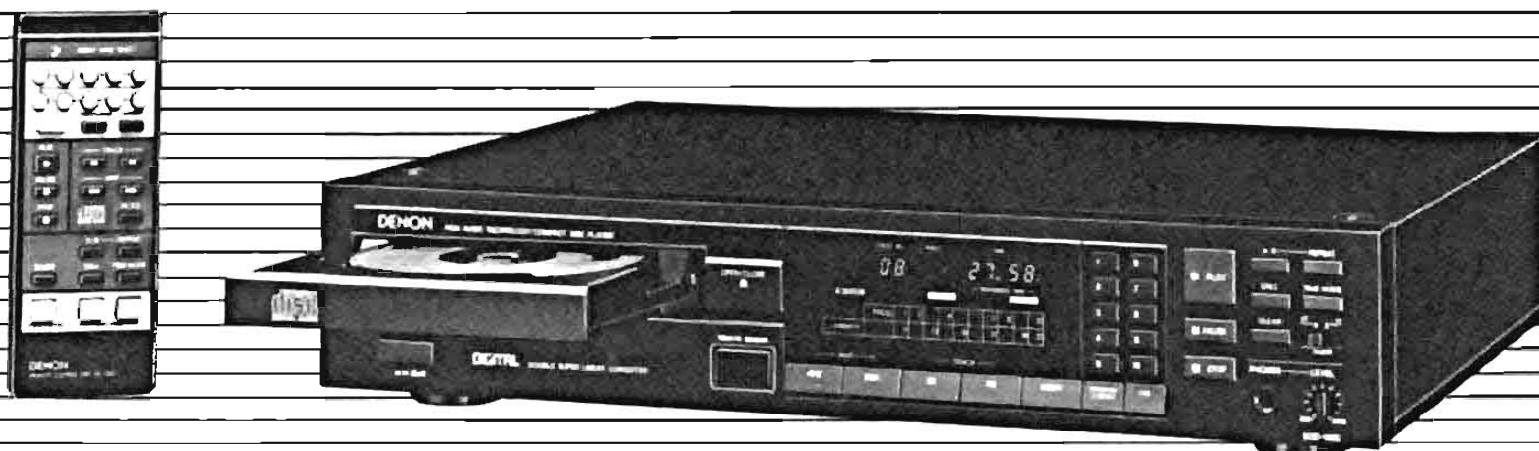

IMPORTANT TO SAFETY

WARNING:

TO PREVENT FIRE OR SHOCK HAZARD, DO NOT EXPOSE THIS APPLIANCE TO RAIN OR MOISTURE.

CAUTION:

1. Handle the power supply cord carefully

Do not damage or deform the power supply cord. If it is damaged or deformed, it may cause electric shock or malfunction when used. When removing from wall outlet, be sure to remove by holding the plug attachment and not by pulling the cord.

2. Do not open the top cover

In order to prevent electric shock, do not open the top cover. If problems occur, contact your DENON dealer.

3. Do not place anything inside

Do not place metal objects or spill liquid inside the CD player. Electric shock or malfunction may result.

Model No. DCD-1500

Serial No. _____

Please, record and retain the Model name and serial number of your set shown on the rating label.

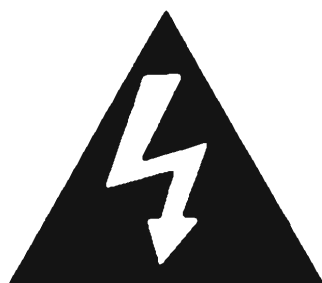

CAUTION

RISK OF ELECTRIC SHOCK
DO NOT OPEN



CAUTION: TO REDUCE THE RISK OF ELECTRIC SHOCK, DO NOT REMOVE COVER (OR BACK). NO USER SERVICEABLE PARTS INSIDE. REFER SERVICING TO QUALIFIED SERVICE PERSONNEL.



The lightning flash with arrowhead symbol within an equilateral triangle is intended to alert the user of the presence of uninsulated "dangerous voltage" within the product's enclosure that may be of sufficient magnitude to constitute a risk of electric shock to persons.



The exclamation point within an equilateral triangle is intended to alert the user of the presence of important operating and maintenance (servicing) instruction in the literature accompanying the appliance.

NOTE: This CD player uses the semiconductor laser. To allow you to enjoy music at a stable operation, it is recommended to use this in a room of 5°C – 35°C.

LABELS

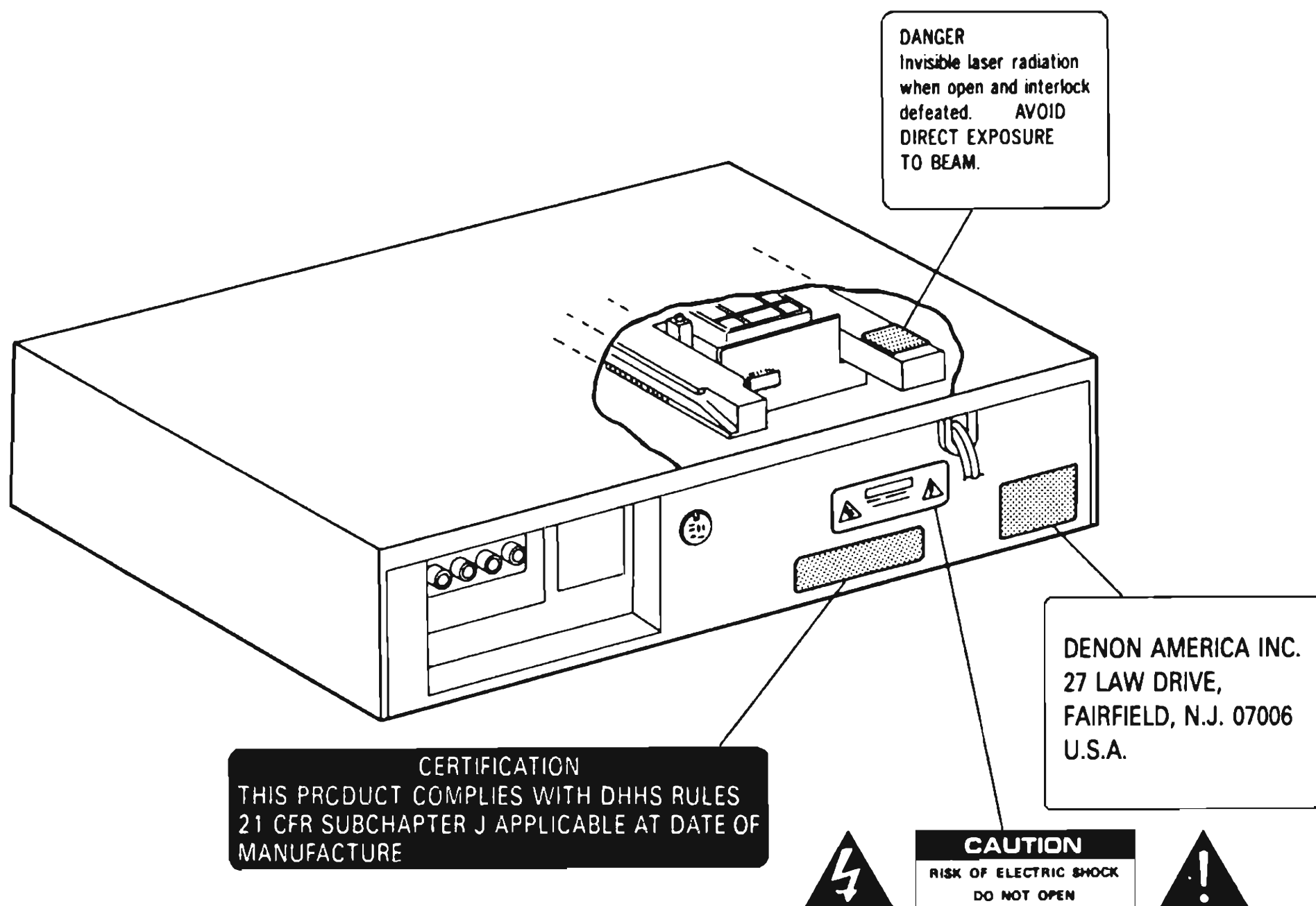

CAUTION – USE OF CONTROLS OR ADJUSTMENTS OR PERFORMANCE OF PROCEDURES OTHER THAN THOSE SPECIFIED HEREIN MAY RESULT IN HAZARDOUS RADIATION EXPOSURE.

THE COMPACT DISC PLAYER SHOULD NOT BE ADJUSTED OR REPAIRED BY ANYONE EXCEPT PROPERLY QUALIFIED SERVICE PERSONNEL.

NOTE

This unit may cause interference to radio and television reception if you do not operate it in strict accordance with this OPERATING INSTRUCTIONS.

This unit complies with Class B computing device rules in accordance with the specifications in Subpart J or Part 15 of the FCC Rules, which are designed to provide reasonable protection against such interference in a residential installation.

If the unit does cause interference to any radio or television reception, try to reduce it by one or more of the following means:

- a) Turn the other unit to improve reception
- b) Move this unit
- c) move this unit away from others
- d) plug this unit respectively into a different AC outlet

* This is a note in accordance with Section 15.838 of the FCC Rules.

Thank you for purchasing the DENON compact disc player. Read the Operating Instructions thoroughly, and operate this player properly.

– TABLE OF CONTENTS –

| | |
|---|--------|
| FEATURES | 5 |
| BEFORE USE | 5 |
| NAMES AND FUNCTIONS OF PARTS | 6~9 |
| CONNECTION | 9 |
| OPENING AND CLOSING THE DISC HOLDER AND LOADING A DISC | 9 |
| REGULAR OPERATION | 10 |
| VARIOUS OPERATIONS | 11~15 |
| ① Playing a desired track | |
| ② Skipping to the next track during playback | |
| ③ Returning to the beginning of the current track during playback | |
| ④ Playing several tracks in the desired order | |
| ⑤ Repeating all tracks | |
| ⑥ Repeating playback of a desired interval between two points | |
| ⑦ Pausing playback at an optional point | |
| ⑧ Skipping playback to find a desired track | |
| ⑨ Finding the indexed part of a track | |
| ⑩ Pausing playback at the beginning of a desired track | |
| PLAYBACK USING THE REMOTE CONTROL | 16~17 |
| TIMER-CONTROLLED PLAYBACK | 18 |
| COMPACT DISC | 18 |
| TROUBLESHOOTING | 19 |
| SPECIFICATIONS | Bottom |

Please check to make sure the following items, aside from the main unit, are packed in the carton.

- (1) Operating Instructions 1
- (2) Connecting Cord 1
- (3) Remote Control Unit 1

FEATURES

The DCD-1500 compact laser disc player utilizes a unique DENON Double Super Linear Converter which prevents deterioration of sound quality in the PCM playback system, assuring accurate reproduction of sound recorded on compact laser discs, in the studio or in live sound production areas. The parts for this high performance disc player have been selected with careful discrimination, to produce realistic playback of the full musical production.

(1) Double Super Linear Converter

This unique DENON system is used to prevent the generation of distortion at zero cross, the main cause of sound deterioration in a PCM playback system, enabling realistic playback of the full musical production.

(2) Wireless remote control accessory

The accessory wireless remote control unit features a variety of functions, including a direct selection and direct programming function, utilizing a ten-key pad, an electronic volume control function, and an A-B interval repeat function, in addition to general operations such as PLAY, STOP, and TRACK.

(3) High performance, built-in digital filter

The DCD-1500 utilizes a dedicated D/A converter for the left and right channels and a double oversampling, high quality 121st digital filter. A built-in, specially developed Computer Analyzed Linear Phase (C.A.L.P.) filter features nearly perfect flat delay characteristics at up to

30 kHz. This ideal analog filter provides clear sound with an excellent rise time.

(4) Dedicated, four power source system circuitry

Four systems — 1) the digital signal control system, 2) the laser pickup and disc servo system, and 3) the audio system, and 4) the display systems — are each driven by a dedicated power source.

The use of a high capacitance condenser in the circuit construction ensures non-interference with plenty of leeway.

(5) Programmable, 20-track selection function

Desired pieces can be selected from those recorded on disc, and their desired order of play programmed, for automatic playback.

(6) DC amp equipped with DC servo

The DC servo amp that provides the superior sound of the DCD-1800 is used in the analog circuitry of the DCD-1500, to accurately reproduce the characteristics of the high speed digital music signal.

BEFORE USE

Remove the transport lock before use.

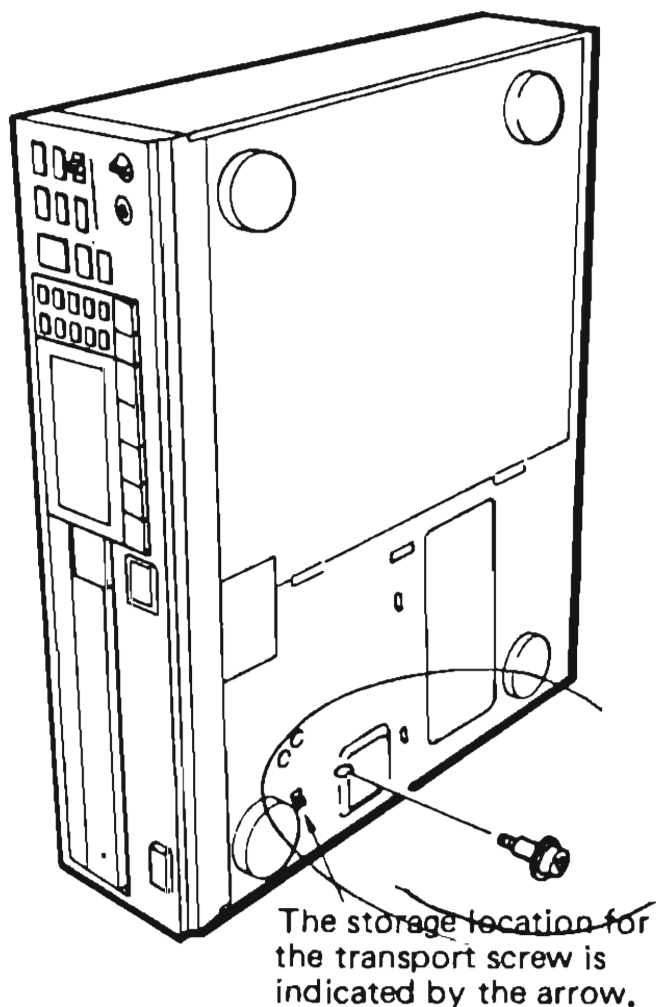

● **Transport lock**

The transport lock is used to prevent the laser pickup device in the CD player from moving while the player is being transported. The location of the transport lock screw is indicated on the bottom side of the player.

● **Use**

Before connecting the power source, stand the player up on its left or right side and remove the screw to the transport lock.

Store the transport screw after its removal by placing it on the hook indicated by the arrow.

Transport

If the player is to be transported again,

(1) Turn on the power supply and open the disc holder to make sure there is no disc left inside. Then close the disc holder.

(2) Turn off the power source. Stand the player up on its side, and fasten the screw on the transport lock into place.

NAMES AND FUNCTIONS OF PARTS

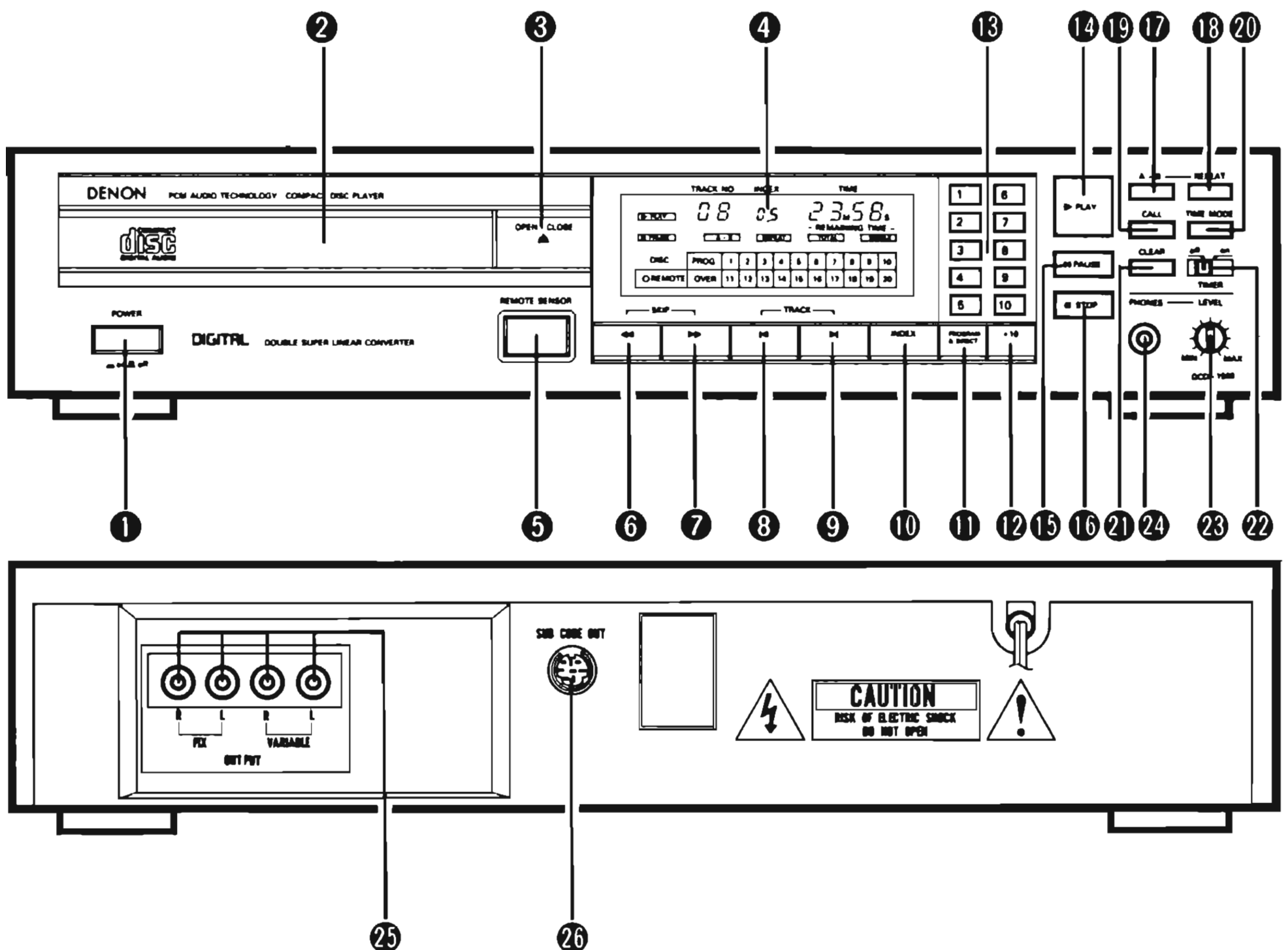

1 Power Switch (POWER)

- Press this switch to turn the power source ON.
- When the power is turned ON, (00) will light up in the TRACK NO section of the display 4. If no disc is loaded at this time, (-----) will be displayed after several seconds.
- If a disc is loaded, the DISC indicator will light, the total number of tracks on the disc will be displayed in the TRACK NO. section of the display, and the total playback time will be displayed under the TIME section. The calendar will light up to display the total number of tracks.

2 Disc Holder

- The disc is loaded into the disc holder for play.
- The disc holder is opened and closed by pressing the disc holder open/close button (▲ OPEN/CLOSE) 3.
- It can also be closed by pressing the play button (▶ PLAY) 14.

3 Disc Holder Open/Close Button (▲ OPEN/CLOSE)

- The disc holder 2 is opened and closed by pressing this button.
- Press the button once to eject the disc holder 2 forward. Press it again to close the holder.
- If the disc holder is closed and a disc has been loaded, the disc is rotated for several seconds, and then the machine enters STOP state. The total number of tracks on the disc and the total playback time are then displayed on the digital display 4.

4 Display

- The display area consists of sections for the track number, the index, the playback time, and the calendar.

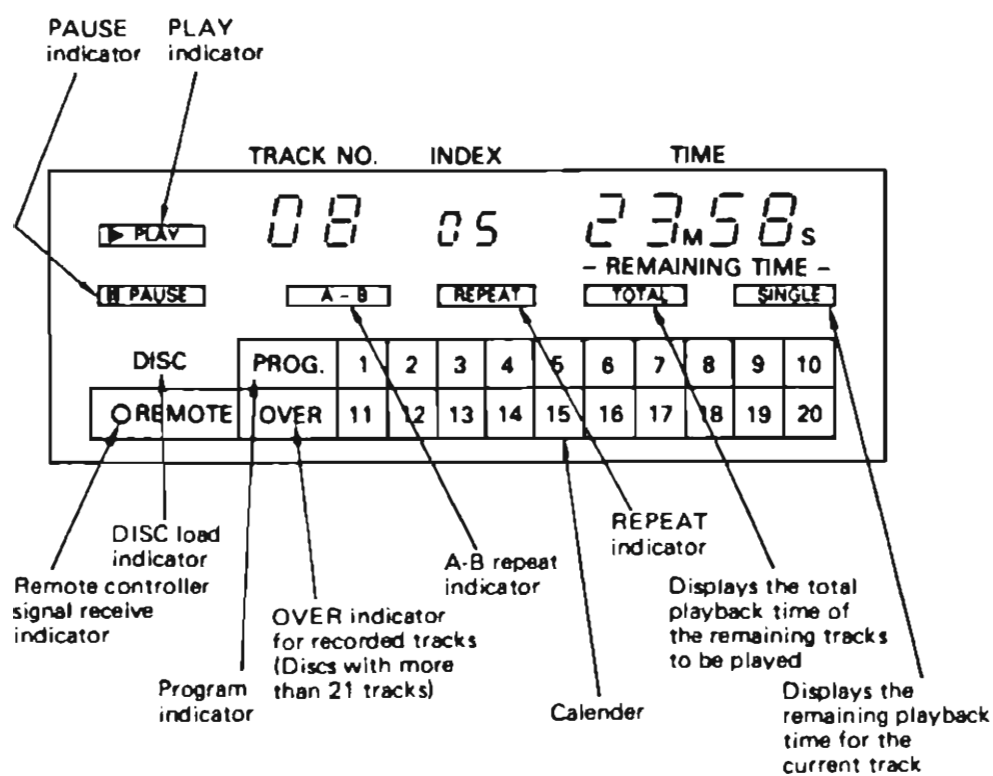

5 Remote Control Photosensitive Window

- This window receives the light transmitted from the wireless remote control unit.
- The RC-1500 wireless remote control unit should be operated while it is pointed in the direction of the photosensitive window.
- When the remote control is operated, the remote control sensor indicator lamp will light in the display area 4.

6 Fast Reverse Skip Button (◀◀)

- Press this button to move playback in fast reverse.
- When the machine is in play, sound will be produced during the time that the button is being pressed and the fast reverse is operating.
- If the button is pressed while the machine is in the pause state, the fast reverse will operate three times faster than the reverse speed when the machine is in the play state. No sound will be produced.

7 Fast Forward Skip Button (▶▶)

- Press this button to move playback in forward.
- When the machine is in play, sound will be produced during the time that the button is being pressed and the fast forward is operating.
- If the button is pressed while the machine is in the pause state, the fast forward will operate three times faster than the fast forward speed when the machine is in the play state. No sound will be produced.

8 Track Button (◀)

- Press this button to move the pickup forward and advance to the beginning of the desired track.
- If the TRACK button is pressed during playback or pause, the pickup moves forward to the beginning of the track that corresponds to the number of times the button was pressed.

9 Track Button (▶)

- Press this button to move the pickup backward, to return to the beginning of the desired track.
- If the TRACK button is pressed during playback or pause, the pickup moves back to the beginning of the track that corresponds to the number of times the button was pressed.

10 Index Button (INDEX)

- Press this button to begin playback at an index number within a track.
- Select the desired index number by using the ten-key pad.
(Refer to page 15 for details.)

11 Program and Direct Button (PROGRAM & DIRECT)

- Press this button to select the memory program function or direct track selection function.
(Refer to page 12 for details.)

12 +10 Button (+10)

- Press this button to select a track number that is larger than 11.
- The +10 button is used in conjunction with the ten-key pad 13. For example, to select track number 15, press the **+10** button and then **5** on the ten-key pad.
- Similarly, to select track number 32, press **+10**, **+10**, **+10** and then press **2**.

13 Ten-key Pad

- These buttons are pressed for direct track selection or to program a selection into memory. For example, to play back the third track using the direct selection function, press **3** on the key pad. Track number 3 will then start to play. To play track number 12, press **+10** and then **2**.
- To use the keypad in program mode, first press the PROGRAM & DIRECT button to enter the correct mode.

14 Play Button (▶PLAY)

- Press this button to play a disc.
- When the PLAY button is pressed, the ▶ PLAY indicator lights, and the number of the track being played, the index number, and the elapsed playback time for that track are displayed. The calendar lights to display the all of the playback tracks. The displayed tracks then go out in order as each finishes playing.
- When playback of the last track has finished, the ▶ PLAY indicator goes out, and the machine enters stop state.
- It is also possible to use the PLAY button to close the disc holder after a disc has been inserted. Playback then begins.

15 Pause Button (II PAUSE)

- Press this button to stop the playback temporarily.
- If the PAUSE button is pressed during playback, the play is stopped temporarily, the PLAY lamp goes out, and the PAUSE lamp lights.
- To end the pause, push the PLAY key **14**.

16 Stop Button (■ STOP)

- Press this button to stop the playback.
- The rotation of the disc stops, and the total number of tracks and the total playback time are read out on the TRACK NO, and TIME sections of the display.
- During programmed playback, the total number of tracks programmed in memory and the total programmed performance time are displayed.

17 A-B Repeat Button (A – B)

- Press this button to perform repeated playback of a desired section between two specified points.
(Refer to page 13 for details.)

18 Repeat Button (REPEAT)

- Press this button to repeat playback.
- When the REPEAT button is pressed, the REPEAT indicator lights and repeated playback is performed for all of the tracks on the disc. During programmed playback, all of the tracks programmed into memory are played repeatedly.

Press the REPEAT button again to cancel the repeat operation.

19 Call Button (CALL)

- Press this button to verify the track numbers that have been programmed into memory.

20 Time Mode Button (TIME MODE)

- This button is used to select the type of information to be read out under the TIME section of the display. Either the elapsed playback time of the current track, the remaining playback time for that track, or the playback time for the remaining tracks on the disc can be selected.

Normally the elapsed playback time of the current track is displayed. If the button is pressed once, the SINGLE indicator lights and the remaining time left to play on the track is displayed. If the button is pressed 'again, the SINGLE indicator goes on, and the TOTAL indicator goes on, and the playback time for the remaining tracks left on the disc is displayed. If the button is pressed once more, the TOTAL indicator goes out and the display returns to the elapsed playback time for that track.

If the button is pressed so that the TOTAL Indicator lights during programmed playback, the playback time for all of the remaining programmed tracks is displayed.

21 Clear Button (CLEAR)

- Press this button to correct the programmed contents of memory.

22 Timer Button (TIMER)

- This button is used in conjunction with an audio timer to perform timer playback at the specified time.

23 Volume adjustment knob

- This knob is used to adjust the output level (volume) of the headphone jack.

24 Headphone Jack (PHONES)

- When using headphones, please listen to them at an appropriate volume.
(Headphones are sold separately.)

25 Output terminal (OUTPUT)

- Connect the output terminal to the input terminal of the amp.
(Refer to page 9 for details on connections.)

26 Sub code output terminal (SUB CODE OUT)

- This output terminal will enable the more effective use of the compact disc player in the future.

CONNECTION

- (1) Connect the accessory pin cord to the output terminal of the player (to R (right) and L (left) of OUTPUT), and to the AUX, TUNER, or TAPE PLAY of the input terminal of the amp (to R and L).

There are two output terminals: a variable output terminal (VARIABLE), and a fixed output terminal (FIX). When the output level is to be varied using the remote control, the VARIABLE terminal must be connected.

- (2) Connect the power cord to a power outlet. If your amp or other equipment has a power supply outlet, the power cord may be connected there. Refer to the operating manual for the amp or equipment to make sure that the capacity of the power source is sufficient.

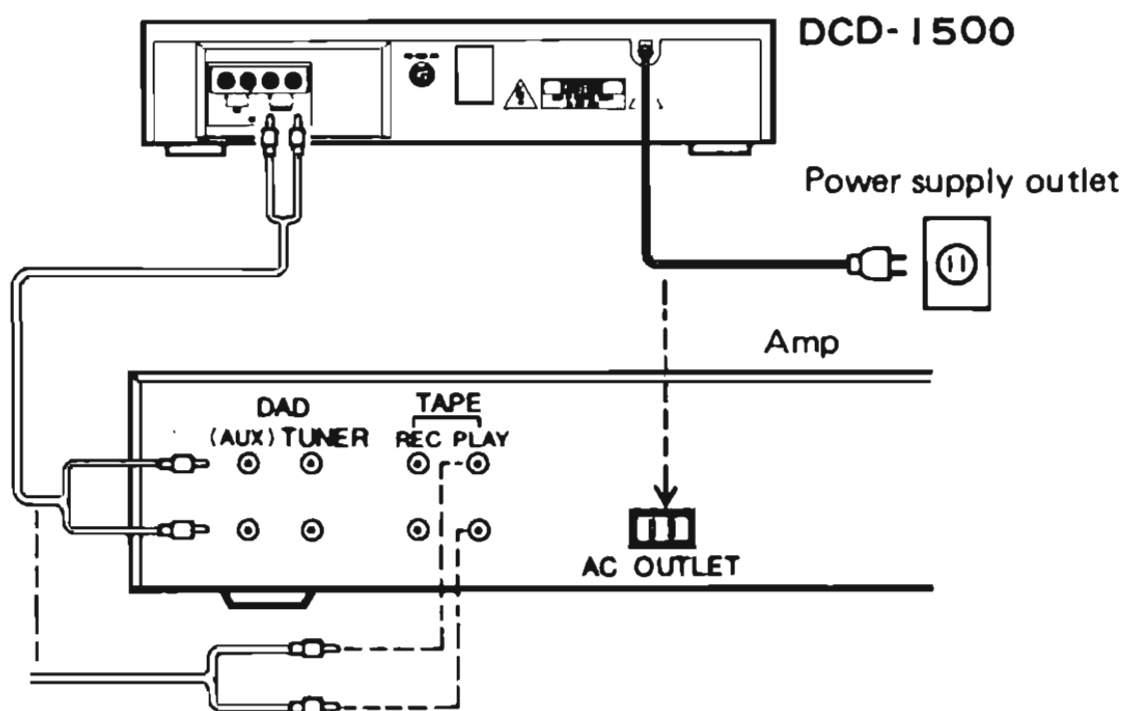

Connection Precautions:

- Turn the power switch of each unit OFF before connecting or disconnecting the pin cord.
- Make certain that the R plug of the pin cord is connected to the R jack of the player or amplifier, and that the L pin plug is connected to the L jack.
- Connect the amp to DAD (AUX), TUNER, or TAPE PLAY.
- Make certain that the pin plugs are inserted all the way in to prevent loose connections.

OPENING AND CLOSING THE DISC HOLDER AND LOADING A DISC

Opening and closing the disc holder (If the power is turned OFF, the disc holder will not operate.)

- ① Press the power switch (POWER) to turn on the power supply.
- ② Press the disc holder open/close button (▲ OPEN/CLOSE).

Caution: Do not hit the button with a pencil, etc.

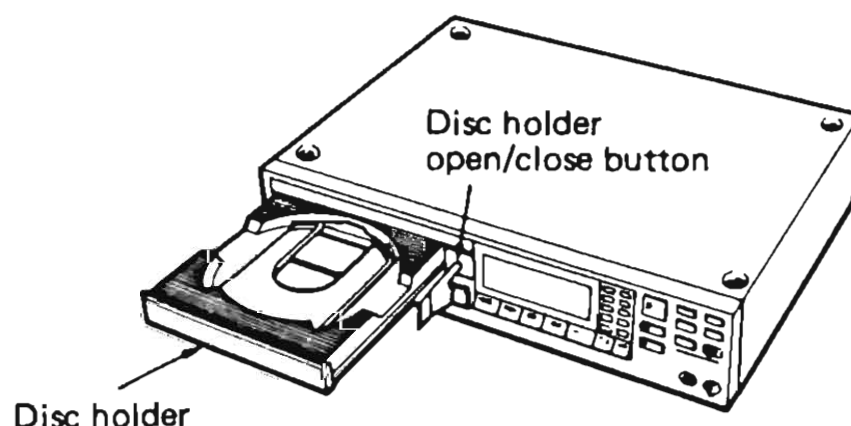

How to load the disc

- Without touching the disc surface, set it in the disc holder with the label up.
- When the disc holder is completely open, place the disc on the disc tray.
- Be certain to place the disc in the guide in the center of the disc holder.
- Press the disc holder open/close button (▲ OPEN/CLOSE). The disc holder will then close automatically.
- When the disc has been loaded, it is automatically rotated for a few seconds and track number(00) is read out on the display. After the rotation stops and the disc loading is complete, the total number of tracks on the disk is displayed under TRACK NO, the total playback time is displayed under TIME. The DISC indicator lights.
- When the disc holder is closed, the disc will be loaded even if the play button (▶ PLAY) or pause button (|| PAUSE) is pushed. If PLAY is pushed at this time, playback automatically begins at the first track.

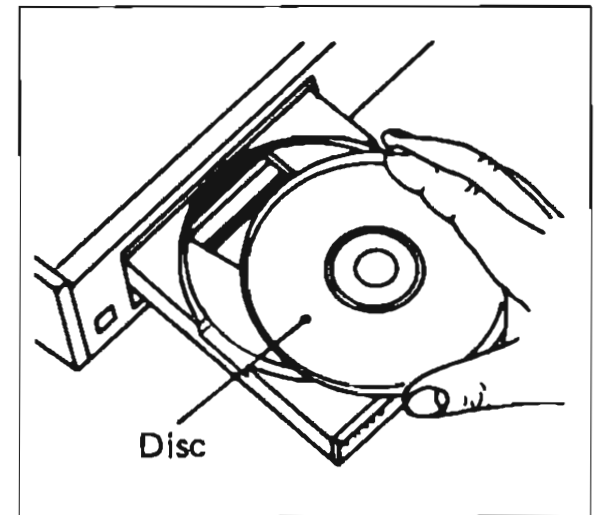

Caution:

- If your finger becomes caught in the disc holder, simply press the disc holder open/close button (▲ OPEN/CLOSE).
- Be careful not to place any foreign objects in the disc tray. This may result in malfunction.

REGULAR OPERATION

Sequential playback is described below.

(1) Starting playback

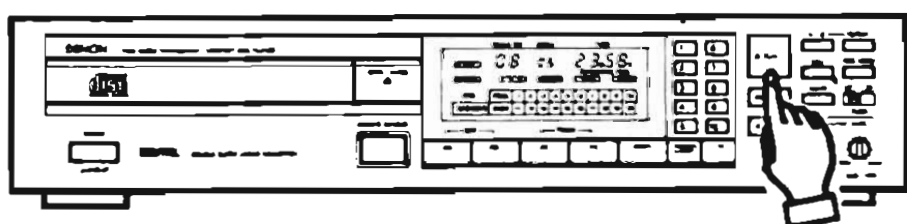

(▶ PLAY)

- ① Turn the power switch ON, and load a disc.
- ② Press the play key (▶PLAY).
 - The track number, index number, and playback time of the track being played are displayed.

(2) Stopping playback

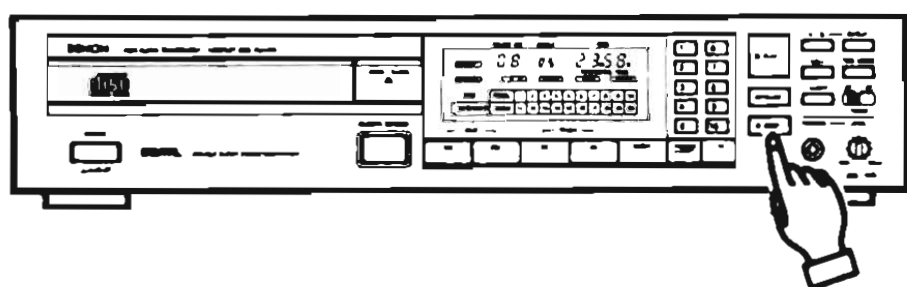

(■ STOP)

- ① Press the stop button (■ STOP).
 - When all of the recorded tracks on the disc have been played, the player stops automatically.

Precautions:

- When no disc is loaded or if a disc has been loaded upside down, (-----) will be displayed after the track number(00) has stopped blinking.

| TRACK NO | | INDEX | | TIME | |
|----------|------|-------|-----|------|-----|
| REPLAY | --- | --- | --- | --- | --- |
| REVERSE | --- | --- | --- | --- | --- |
| DISC | PROG | 1 | 2 | 3 | 4 |
| OREMOTE | OVER | 11 | 12 | 13 | 14 |
| | | 15 | 16 | 17 | 18 |
| | | 19 | 20 | | |

- If the disc is warped or dirty and the information on its innermost track cannot be read properly, the display will appear as shown in the diagram below. This may cause delays in the location of the beginning of a track.

| TRACK NO | | INDEX | | TIME | |
|----------|------|-------|-----|------|-----|
| REPLAY | 08 | | | 23 | 58s |
| REVERSE | --- | --- | --- | --- | --- |
| DISC | PROG | 1 | 2 | 3 | 4 |
| OREMOTE | OVER | 11 | 12 | 13 | 14 |
| | | 15 | 16 | 17 | 18 |
| | | 19 | 20 | | |

Normal appearance

| TRACK NO | | INDEX | | TIME | |
|----------|------|-------|-----|------|-----|
| REPLAY | 01 | | | 00 | 00s |
| REVERSE | --- | --- | --- | --- | --- |
| DISC | PROG | 1 | 2 | 3 | 4 |
| OREMOTE | OVER | 11 | 12 | 13 | 14 |
| | | 15 | 16 | 17 | 18 |
| | | 19 | 20 | | |

Improper read

VARIOUS OPERATIONS

In addition to regular operation, the following special operations are provided:

| | Index | Page |
|---|-------------------|------|
| ① Playing a desired track | Direct selection | 11 |
| ② Skipping to the next track during playback | Quick selection | 11 |
| ③ Returning to the beginning of the current track during playback | | |
| ④ Playing several tracks in the desired order | Program selection | 12 |
| ⑤ Repeating all tracks | Repeat playback | 13 |
| ⑥ Repeating playback of a desired interval between two points | A-B repeat | 13 |
| ⑦ Pausing playback at an optional point | Pause | 14 |
| ⑧ Skipping playback to find a desired track | Skip monitor | 14 |
| ⑨ Finding the indexed part of a track | Index search | 15 |
| ⑩ Pausing playback at the beginning of a desired track | Pause | 15 |

① Playing a desired track Direct selection

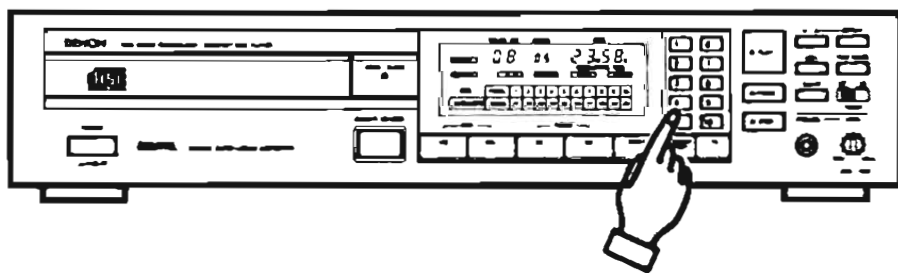

Enter the track number of the track you wish to play using the ten-key pad. For example, if you wish to play track 4, press **4**; if you wish to play track 12, press **+10** and **2**. Playback will begin at that track.

② Skipping to the next track during playback Quick selection

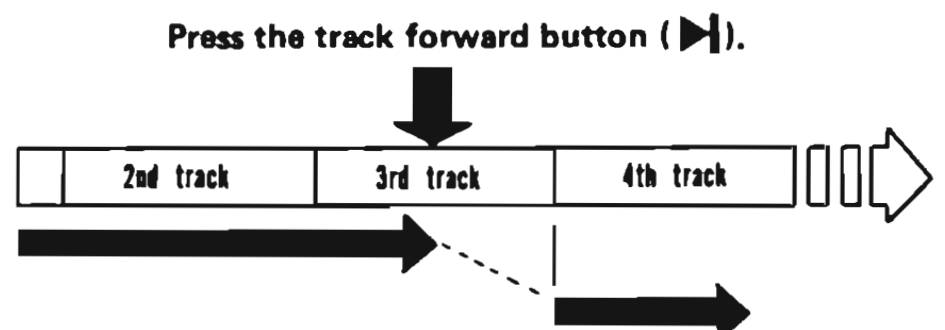
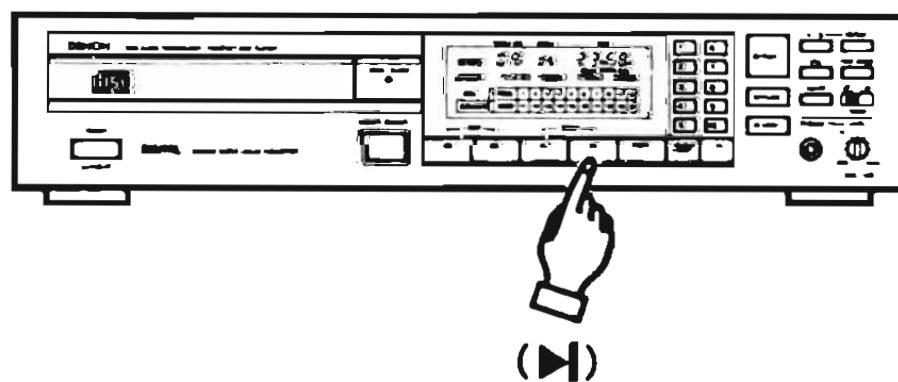

Press the track forward button (▶).

- The track forward button can be pressed during the search operation for a selection, to forward the disc to the beginnings of subsequent tracks in sequence.

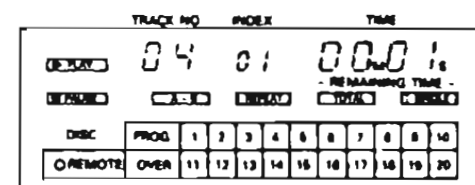

③ Returning to the beginning of the current track during playback **Quick selection**

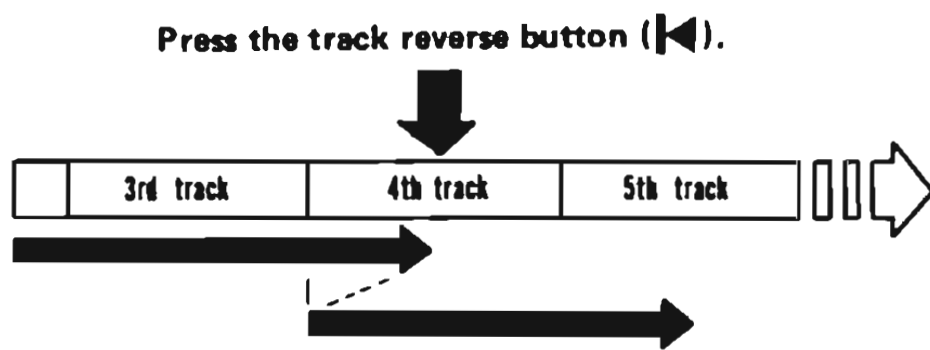
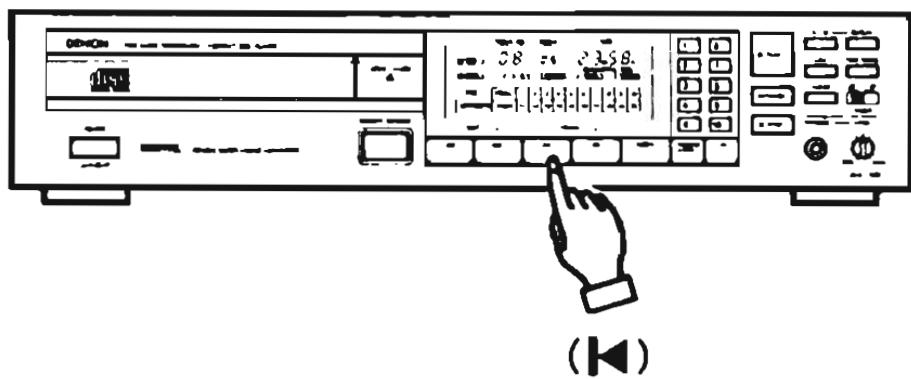

Press the track reverse button (◀).

- The track reverse button can be pressed during the search operation for a selection, to forward the disc to the beginnings of preceding tracks in sequence.

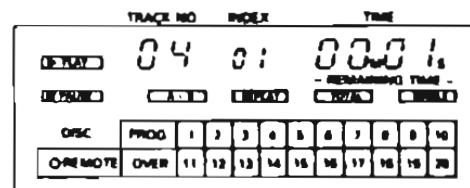

④ Playing several tracks in the desired order **Program selection**

- A desired track can be selected from those recorded on the disc, and tracks can be programmed to be automatically played back in a desired order.
- Programming can be performed for a maximum of 20 tracks.

(1) Programming

(2) Confirming a programmed track

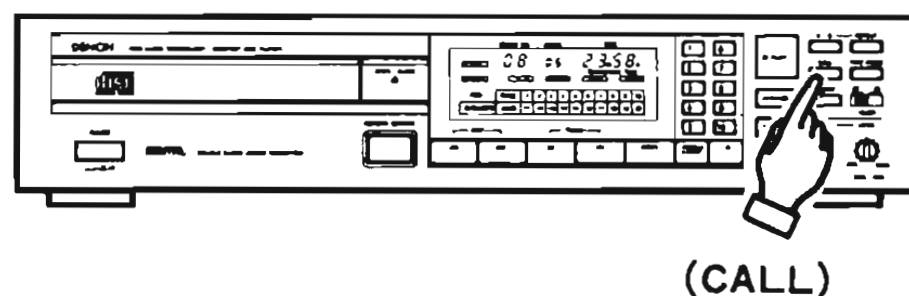
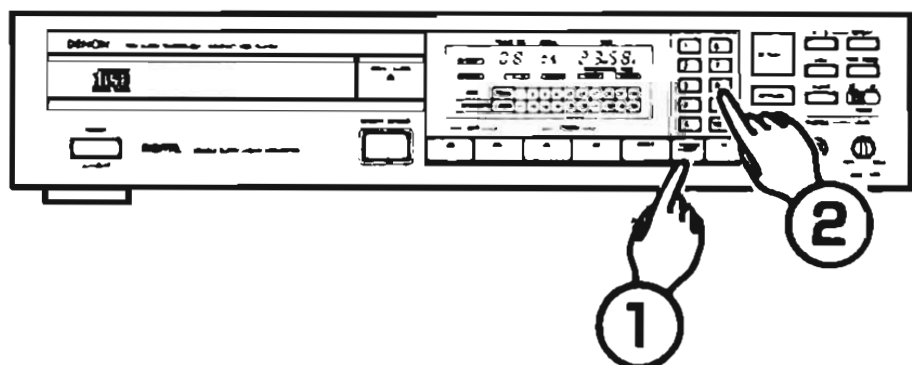

(PROGRAM & DIRECT)

(CALL)

- When the PROGRAM & DIRECT button is pressed, the **PROG** lamp lights. Use the ten-key pad and the **+10** button to select the tracks to be programmed into memory. For example, to program the 3rd track, the 12th track, and the 7th track into memory:

Press the following buttons: **PROGRAM & DIRECT**, **3**, **+10**, **2**, **7**. For each specified track, the calendar will light to display the track, the track number will be displayed under **TRACK NO.**, the number of tracks programmed into memory will be displayed under **INDEX**, and the total playback time for the programmed tracks will be displayed under **TIME**.

- Press the call button (CALL). Press the call button successively to display the programmed contents of the memory in order.

(3) Correcting the programmed contents of memory

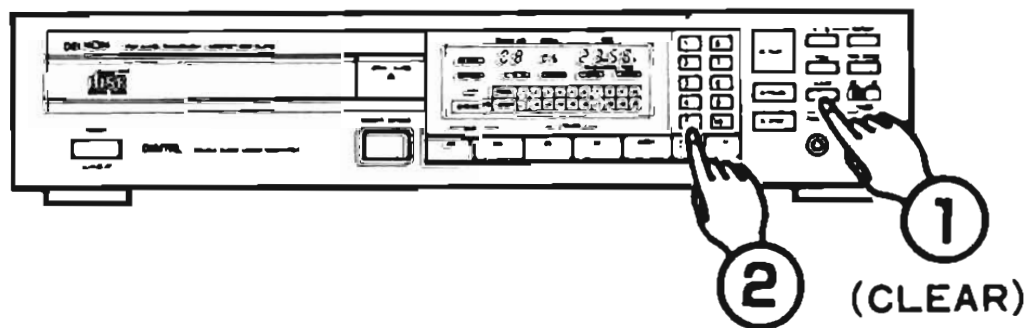

(CLEAR)

- The **OVER** indicator will light if a disc is loaded that has more than 21 tracks recorded on it.
- More than 21 tracks cannot, however, be programmed into memory. The **OVER** indicator will not light in this case.

- To correct a track number programmed into memory, push the **CLEAR** button and then enter the correct track number. The last programmed track will be changed to the correct track. To erase a track number during programming, call that track number using the **CALL** button, and then press the **CLEAR** button to erase it.

(4) Programmed playback

- When the play button (▶ PLAY) is pressed, playback begins, and follows the programmed order of tracks.

(5) Erasing the entire contents programmed into memory

- If the PROGRAM & DIRECT button is pressed once more, the entire contents programmed into memory will be erased.

Pressing the disk holder open/close button (▲ OPEN/CLOSE) will also erase the entire contents programmed into memory.

- If the PROGRAM & DIRECT button is pressed during programmed playback, the programmed contents of memory will be cleared, and continuous playback will begin, starting at the current track and continuing to the last track.

Precautions:

- If programming is performed during playback or in pause state, the current track being played is entered as the 1st track stored in memory.
- Additional programming can be performed at this time, but the number of programmed tracks and the total playback time will not be displayed.
- Direct track selection cannot be performed during programmed playback. If a track number is entered from the ten-key pad, that track number is entered after the last track that is programmed into memory.
- Programming is possible while the disc holder is open. In this case a track number that is larger than the number of tracks recorded on the disc can be programmed into memory. When playback begins, the track number that is higher than the number of tracks on the disc is automatically erased from the programmed memory.

5 Repeating all tracks Repeat playback

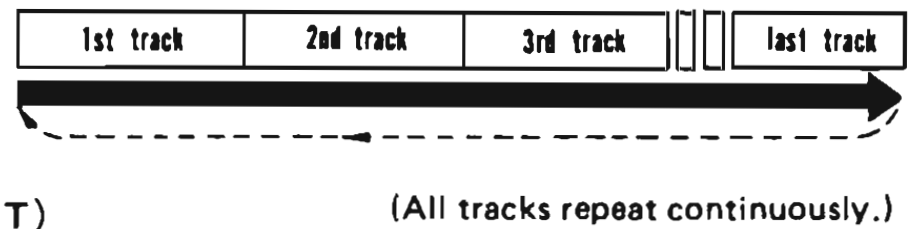
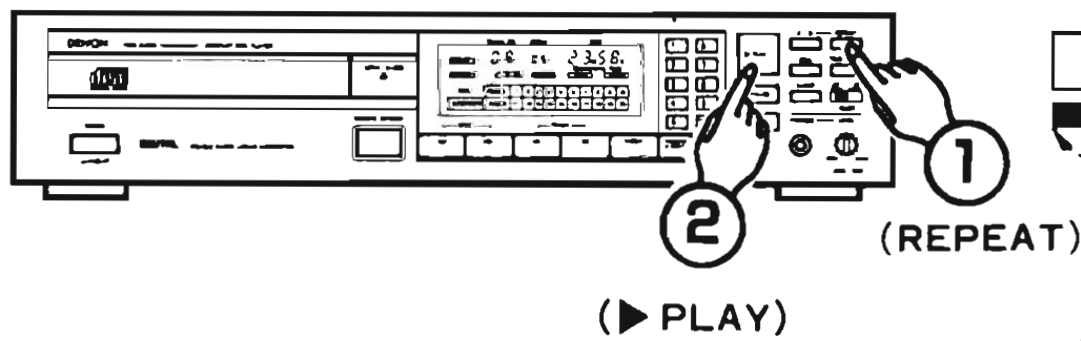

- When the repeat button (REPEAT) is pressed, the REPEAT indicator lights.
- * The order in which ① and ② are performed is optional.
- All tracks can also be repeated by pressing the repeat button (REPEAT) during playback.

- To cancel the repeat playback specification, press the repeat button (REPEAT) again. It can also be cancelled by pressing the stop button (■ STOP).
- If the repeat button (REPEAT) is pressed during programmed playback, the player repeats the programmed tracks.

6 Repeating playback of a desired interval between two points A-B repeat

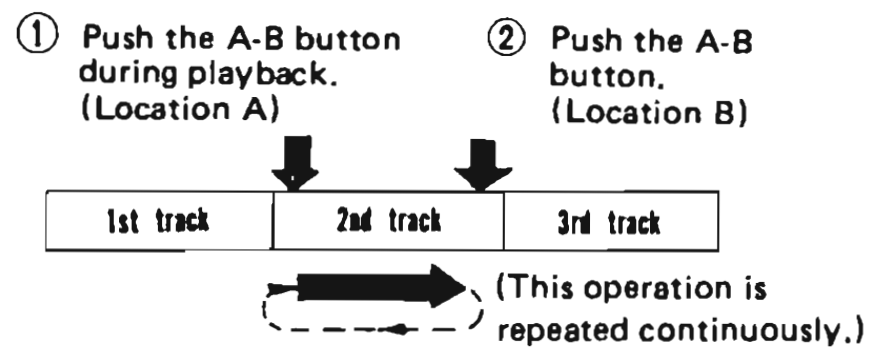
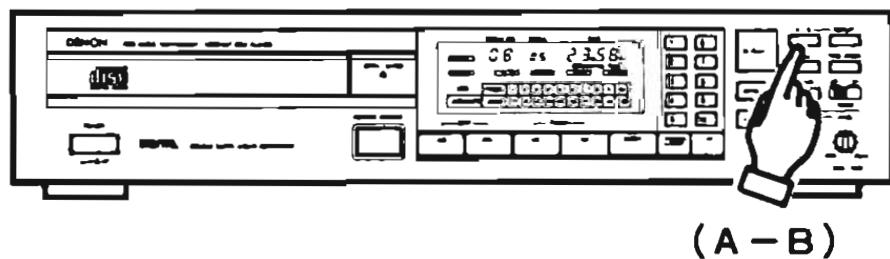

- * When the A-B button is pressed at location A, the A-B indicator blinks on and off. When it is pressed at location B, the A-B indicator remains lit.
- While listening to the disc play, push the A-B button at location A where repeated playback is to begin. Push the button again at location B where the repeated playback is to end. The player returns to position A and begins

- repeated playback of that section.
- To cancel the repeated playback between the two points, press the A-B button once more. The indicator will go out, and the player returns to normal playback mode.
- The A-B repeat function cannot be used together with the normal repeat function.

7 Pausing playback at an optional point Pause

- Playback can be temporarily halted and then restarted from the same location on the track.

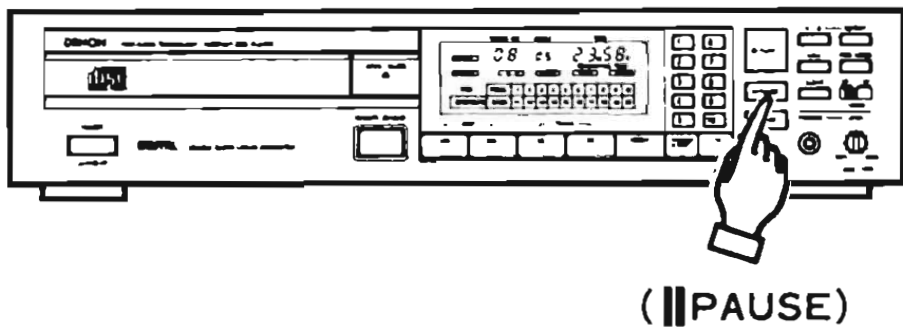

① Press the pause button (|| PAUSE).
(Playback halts temporarily)

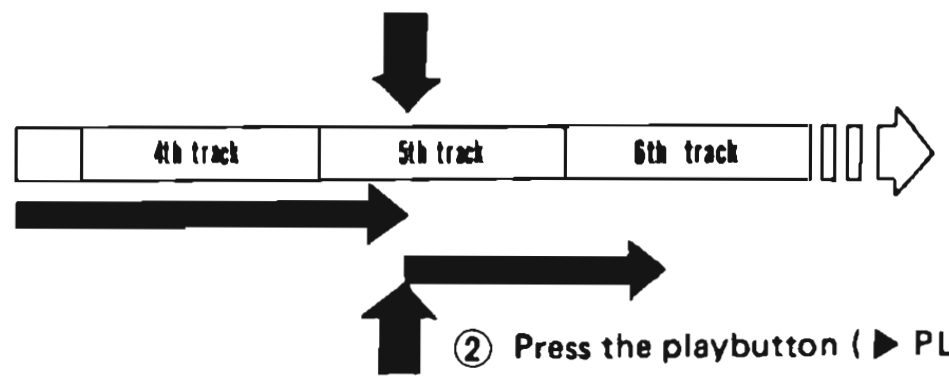

② Press the play button (▶ PLAY).

* To restart playback, press the play button (▶ PLAY).

8 Skipping playback to find a desired track Skip monitor

- This function is used to perform skip listening. Skip listening can be used to locate a desired section in a long piece and begin playback from there.
- After using the skip monitor to find the desired location, the user releases fast forward skip button (▶▶) or the fast reverse skip button (◀◀) to begin normal playback.

(1) Fast forward skip monitor

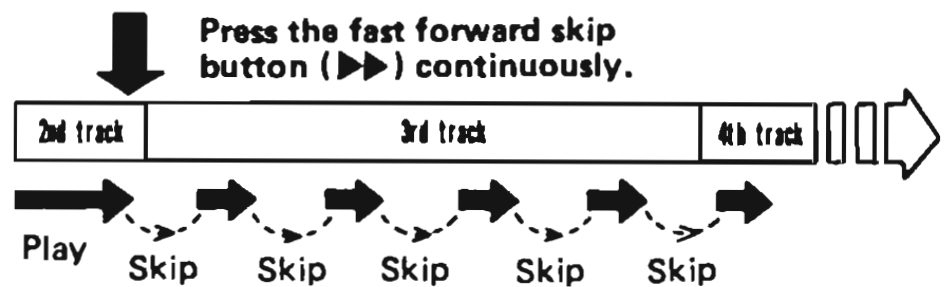
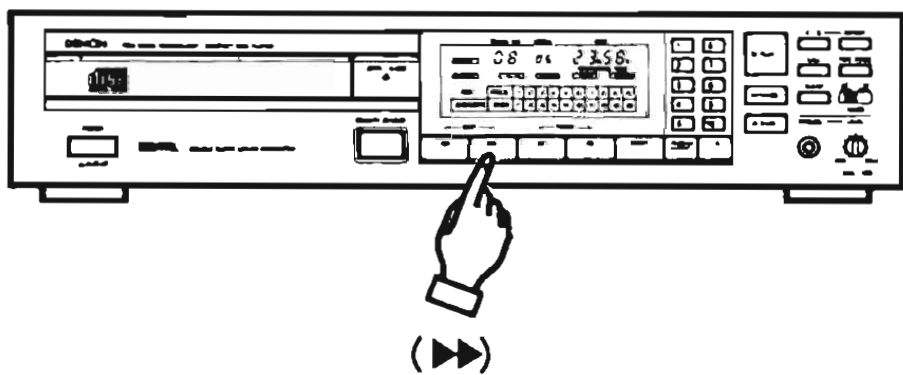

- ① Skip listening can be performed during playback by continuously pressing the fast forward skip button (▶▶).
- The track number and index number of the track that is being fast forwarded, and the elapsed playback time for the track are read out on the display.

- When the fast forward skip button is pressed continuously until the end of the last recorded track, track number (]]]) is displayed and the skip monitor stops. To return to a track for playback, press the fast reverse skip button (◀◀) until the (]]]) on the display changes, and then proceed as desired.

(2) Fast reverse skip monitor

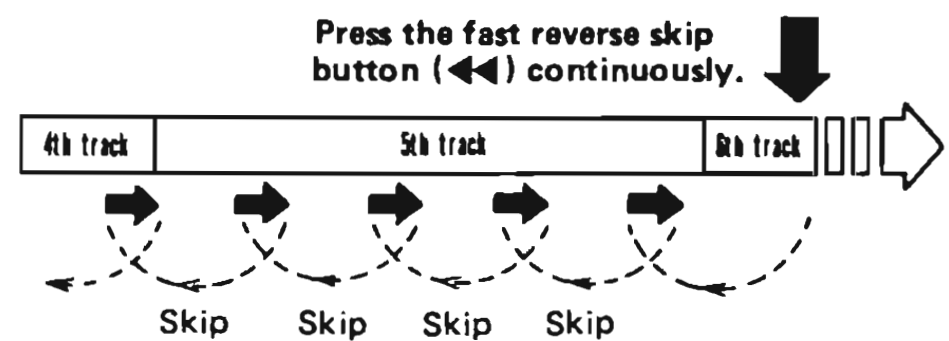
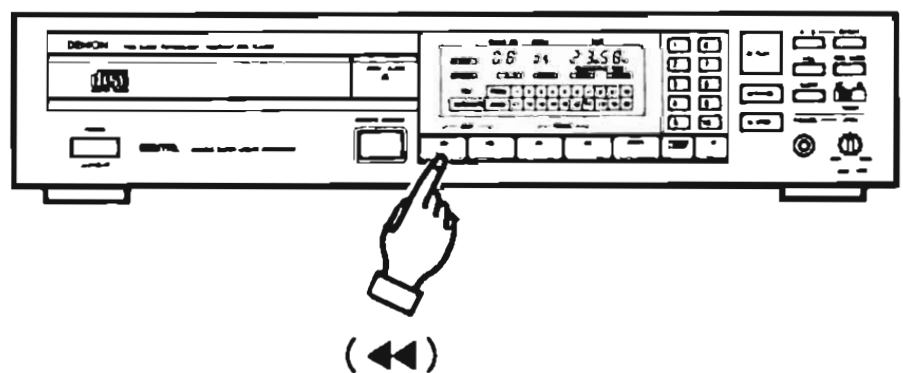

- ① Skip listening can be performed during playback by pressing the fast reverse skip button (◀◀) continuously.
- The display responds in the same way as when the fast forward skip button is pressed.

- When the fast reverse skip button is pressed until the disc returns to the start of the first recorded track, ([[[) is read out on the display, and the skip monitor stops. To return to a track for playback, press the fast reverse skip button (▶▶) until track number ([[[) on the display changes, and then proceed as desired.

⑨ Finding the indexed part of a track **Index search**

- It is possible to select an indexed part of a track and move to the beginning of it.

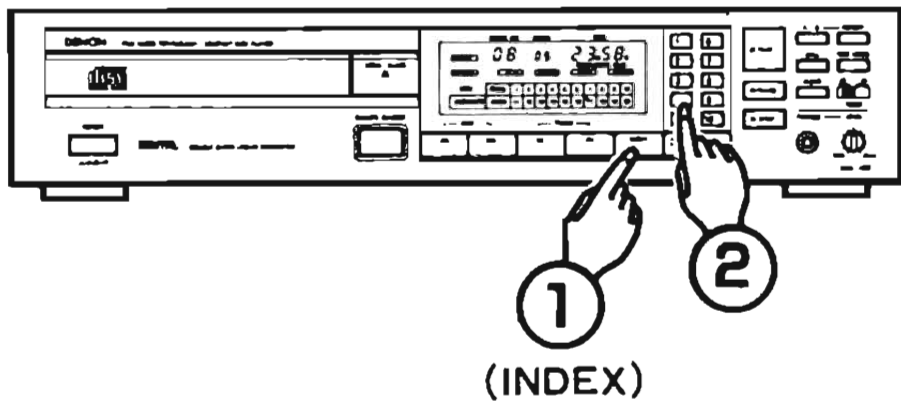

- ① Press the index button. The TRACK NO. section of the display will blink on and off.
- ② Input the track number from the ten-key pad. The INDEX section of the display will blink on and off. Input the desired index number. Playback will begin at the specified index number.

For example, to listen to a disc starting at the 2nd index on its 3rd track, press the buttons: **INDEX**、**3**、**2**.

CAUTION:

- To specify an index in the track that is currently being played, push the index button (INDEX) during the playback.

Notes on index search

- Indexing is the division of a track into smaller sections, each of which is assigned an index number.
- Refer to the user's guide provided with the disc for information on its indexing before playback.
- If an index search is performed for an index number that is not listed in the user's guide, playback begins at the last index number on the track.

⑩ Pausing playback at the beginning of a desired track **Pause**

(1) Direct selection to set the beginning of a track

- Use direct selection to set the beginning of the desired track, and then set the player in pause. This is convenient when singing along with recorded music.

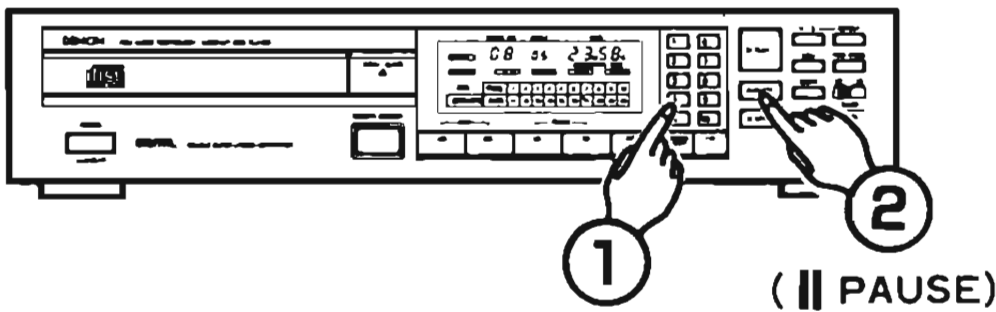

- ① Use the ten-key pad to set the desired track.
- ② Press the pause button (|| PAUSE).
 - To start playback, press the play button (► PLAY).

(2) Programmed selection to set the beginning of a track

- After programming selected tracks into memory, press the pause key (|| PAUSE). The player moves to the first track programmed into memory, and then pauses.

PLAYBACK USING THE REMOTE CONTROL

The accessory RC-1500 remote control unit is used to control the CD player from a distance.

(1) Inserting the dry cell batteries

- ① Remove the rear cover on the remote control unit.

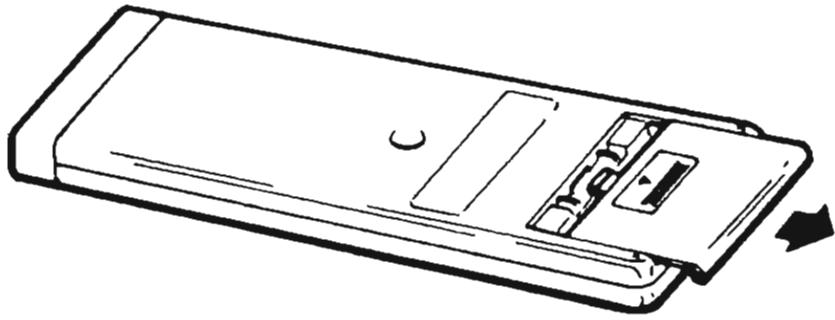

- ② Insert two SUM-4 (standard size 4) dry cell batteries as shown in the diagram on the battery supply unit.

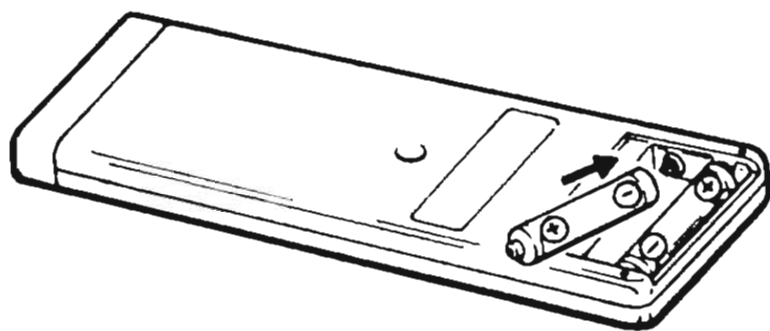

- ③ Replace the rear cover.

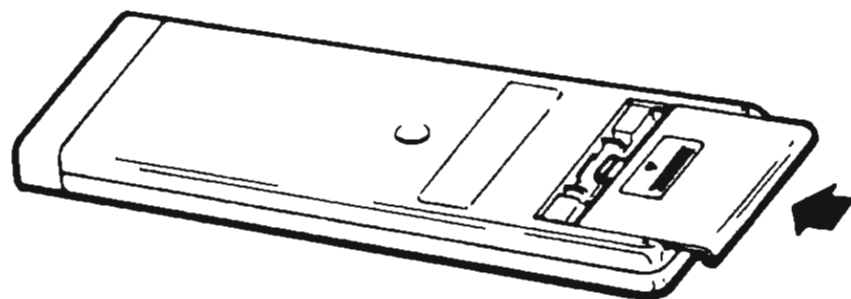

(2) Directions for use

- Operate the remote control unit while it is pointed toward the photosensitive window, as shown in the diagram below.

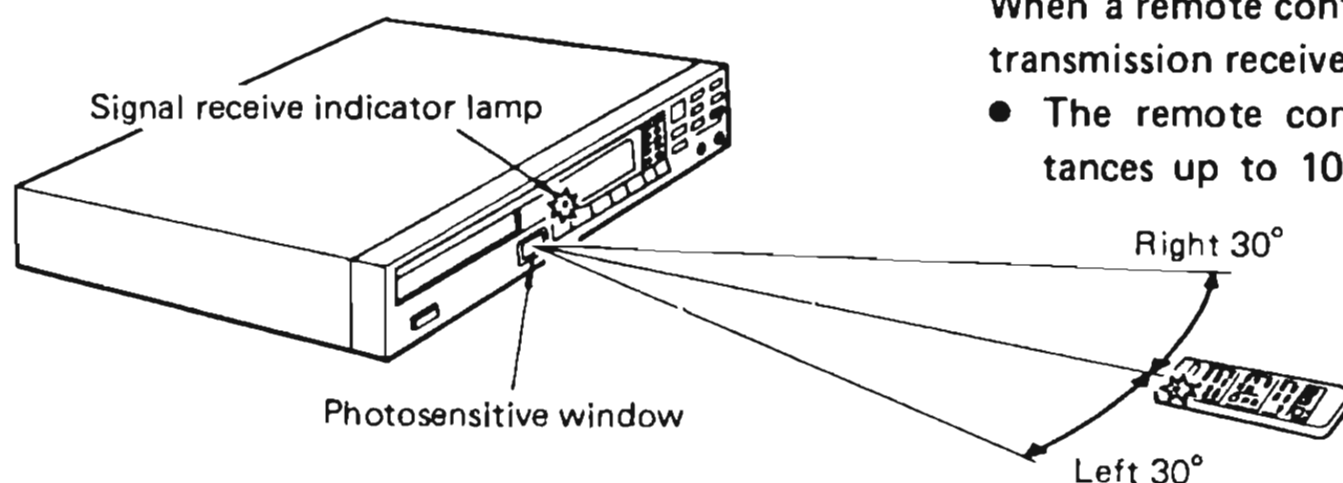

When a remote control signal is received, the signal transmission receive indicator lamp lights.

- The remote control unit can be used at distances up to 10 meters in a straight line away from the player. This distance will decrease if there are obstructions in the way of the transmission or if the light shaft is not directed straight at the player.

Notes on Operation

- Do not press the operating buttons on the player and the remote control unit at the same time. This will cause misoperation.
- Operation of the remote control will become less effective if the infrared photosensitive window is exposed to strong light or if there are obstructions between the remote control unit and the photosensitive window.

Notes on Use of the Batteries

- The remote control unit uses standard size 4 dry cell batteries.
- The batteries will need to be replaced approximately once a year. This will depend upon how often the remote control is used.
- If, in less than a year from the time new batteries were inserted, the remote control fails to operate the disc player from a near-by position, or if the indicator lamp for remote signal transmission does not light or is faintly lit, it is time to replace the batteries.
- Insert the batteries properly, following the diagram on the remote control battery supply unit, and making sure to align the plus and minus sides of each battery.
- Batteries are prone to damage and leakage. Therefore:
 - Do not combine new batteries with used ones.
 - Do not combine different types of batteries.
 - Do not jumper the opposite poles of the batteries, expose them to heat or break them open, or put them into open fire.
- When the remote control is not to be used for a long period of time, remove the batteries from the unit.
- If the batteries have leaked, remove any battery fluid from the inside of the battery supply unit by wiping it out thoroughly, and insert new batteries.

- The control functions of the remote control unit are identical to the operations of the main player unit. However, it is not capable of controlling the following operations:

1. Power source ON/OFF
2. Volume adjustment of the headphones

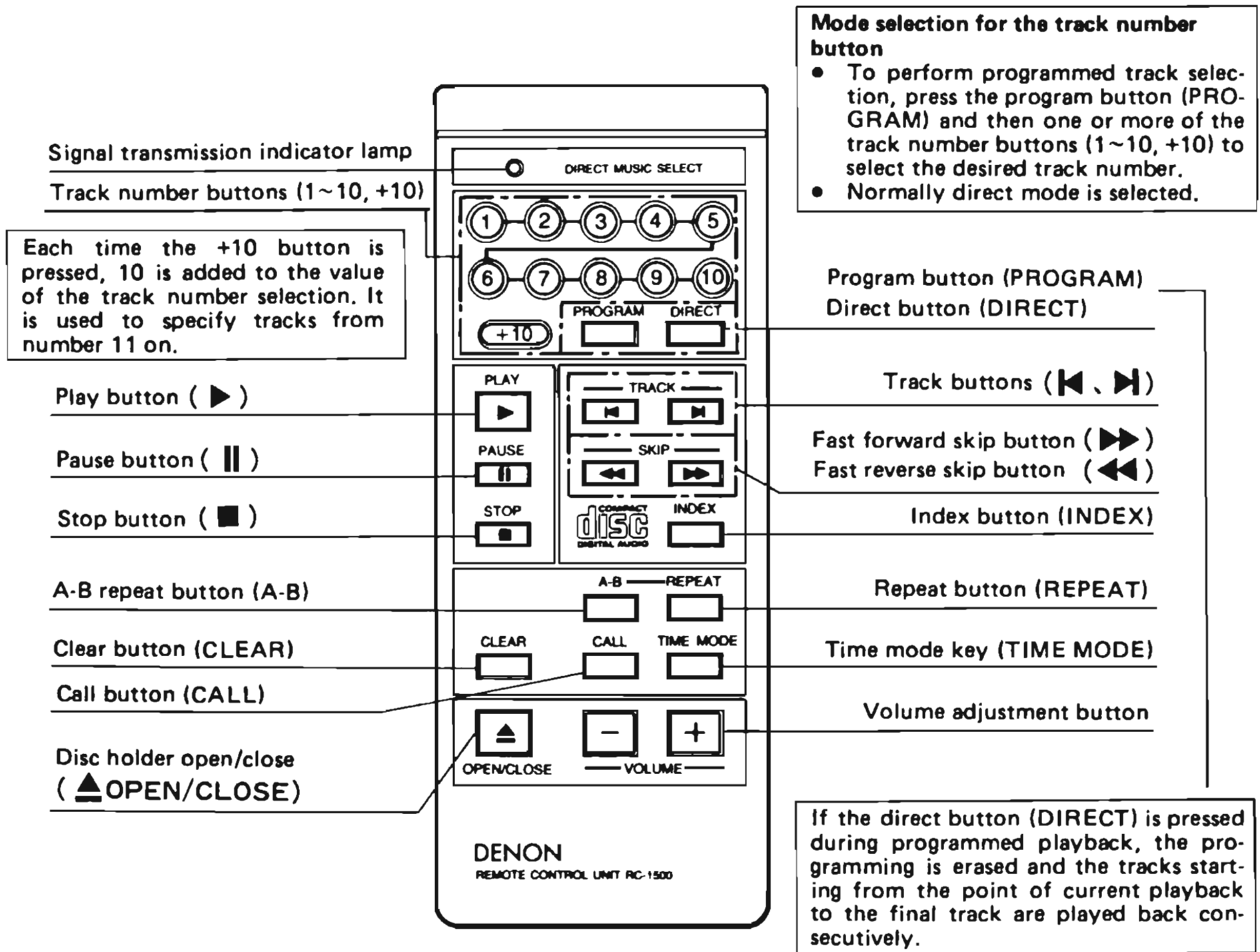

- **Direct track selection**

In normal playback, one or more of the track number buttons (1 ~ 10, +10) is pressed to make a direct selection of the desired track and play it back.

- **Programmed track selection** (Programming is not possible during playback.)

Press the program button (PROGRAM) and then one or more of the track buttons (1 ~ 10, +10).

Example: PROGRAM → 3 → +10, 1 → 5 →

(Programs the 3rd track, the 11th track, the 5th track into memory.)

To erase the programming, press the direct button (DIRECT).

- **How to push the track number buttons**

To select tracks up to the 10th track, push one of the track number buttons from 1 ~ 10. For the 11th track on, push the +10 button and then one of the buttons from 1 ~ 10. (Example: To select track number 22, push the +10 button two times and then the 2 button.)

- **The volume adjustment button can only be operated from the remote control unit.**

The set volume level is retained even after the power supply is turned off, for up to one month. If the power supply has not been turned on in at least a month, the set volume automatically returns to its minimum level. If this occurs, simply reset the volume to the desired level.

(Refer to page 9 for details.)

TIMER-CONTROLLED PLAYBACK

■ Operation

1. Turn on the power switches to all the components in the system.
2. Set the input selector switch of the amplifier to correspond to the connection terminal.
3. Make sure that a disc is loaded in the disc holder.
4. Check the current time, and set the audio timer for the desired time.
5. Turn the timer switch on the player ON.
6. Turn the audio timer ON.
The power supply for each component connected to the timer will go off.
7. At the specified time, the power to each component goes on, and playback begins from the first track.

The ON state of the timer switch is retained from the time the power supply is turned on to when the playback begins. If the power supply is turned on and there is no disc loaded in the player, playback will automatically begin after the disc holder has been opened, a disc loaded, and the disc holder is closed.

Caution:

- If the power supply is turned on while the timer is in ON state, playback will automatically begin when the loader is closed after the first time a disc is loaded (only the first time).

■ Connection

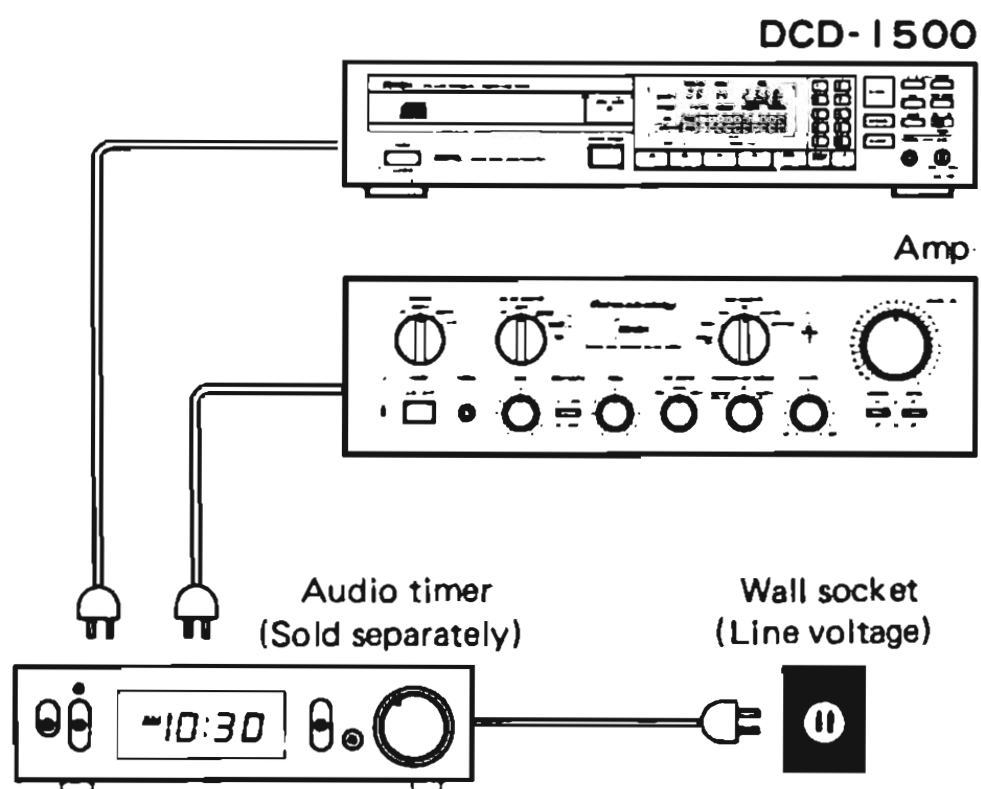

COMPACT DISC

1. Precautions on handling compact discs

- Do not allow fingerprints, oil or dust to contact the surface of the disc. If it is dirty, wipe it off with a soft dry cloth. Denon's AMC-12 CD cleaner is recommended.
- Do not use benzene, thinner, water, record spray, electrostatic-proof chemicals, or silicone-treated cloth to clean discs.
- Always use care in handling discs to prevent damaging the surface; in particular when removing a disc from its case or returning it.
- Do not bend.
- Do not apply heat.
- Do not enlarge the hole in the center of the disc.
- Do not write on the label (printed side) with a hard-tipped implement such as a pencil or ball-point pen.
- Condensation will form if a disc is brought into a warm area from a colder one, such as outdoors in winter. Do not attempt to dry the disc with a hair dryer, etc.

2. Precautions on storage

- After playing a disc, always unload it from the player.
- Always return a disc to its proper case to prevent it from becoming dirty or damaged.
- Do not place discs in the following types of areas:
 - 1) Areas exposed to direct sunlight for a considerable time.
 - 2) Areas subject to accumulation of dust or high humidity.
 - 3) Areas affected by heat from indoor heaters, etc.

TROUBLESHOOTING

If the player does not seem to be functioning properly, check the following:

Disc holder doesn't open or close.

- Is the power switch ON?
- Is the screw on the transport lock removed? See page 9

When a disc is loaded, (— — — —) is not displayed.

- Is the disc loaded properly? See page 10

When the play button (▶) is pressed, playback does not start.

- Is the disc dirty or scratched? See page 18

There is no sound, or it is distorted.

- Is the output cord properly connected to the amplifier? See page 9
- Are the amplifier controls properly adjusted and set?

The specified section of the disc does not play normally.

- Is the disc dirty or scratched? See page 18

Programmed playback does not operate.

- Was programming done properly? See page 12 and 17

Index search does not operate. (Only 1 is displayed.)

- Was the index search performed properly? See page 11
- Check to make sure that there is more than one index on the desired track.

The remote control unit does not operate the disc player properly.

- Have the dry cell batteries run out? See page 16
- Is the remote control being operated too far away from the player? See page 16

SPECIFICATIONS

AUDIO

| | |
|------------------------|--|
| No. of channels: | 2 channels |
| Frequency response: | 5 ~ 20,000 Hz ± 0.3 dB |
| Dynamic range: | Above 96 dB |
| Signal-to-noise ratio: | Above 96 dB |
| Harmonic distortion: | 0.0025% (1 kHz) |
| Separation: | 95 dB (1 kHz) |
| Wow and flutter: | Less than the measuring limit ($\pm 0.001\%$ W. peak) |
| Output voltage: | 2.0 V |

DISCS

| | |
|---------------|---|
| | Compact discs are used. |
| Playing time: | 60 min/single side (Maximum 79.8 min/single side) |
| Diameter: | 120 mm |

SIGNAL FORMAT

| | |
|------------------------|------------------------|
| Sampling frequency: | 44.1 kHz over sampling |
| Quantization: | 16 bit linear/channel |
| Transmission bit rate: | 4.3218 M bits/sec |

PICKUP

| | |
|--------------------|---|
| System: | Objective lens drive system, laser pickup |
| Lens drive system: | Two-dimensional parallel drive |
| Light source: | Semiconductor laser |
| Wavelength: | 780 nm |

GENERAL CHARACTERISTICS

| | |
|--------------------|--|
| Power supply: | 120 V AC, 60 Hz |
| Power consumption: | 17 W |
| Dimensions: | 434 (17.1 in) W x 89 (3.5 in) H x 350 (13.8 in) D mm |
| Weight: | 6.0 kg |

FUNCTIONS AND DISPLAY

| | |
|------------------|--|
| Functions: | Direct selection, quick selection, programmed selection, repeat playback pause, skip monitor, index search, A-B repeat |
| Display: | Track number, index number, time, and program |
| Other functions: | Headphone jack (variable level), Variable level/fixed level output terminal |

REMOTE CONTROL UNIT

| | |
|------------------------|--|
| Remote control system: | RC-1500 Infrared pulse system |
| Power supply: | 3 V DC Two SUM-4 (standard size four) dry cell batteries |
| External dimensions: | 60 (2.4 in) W x 150 (5.9 in) H x 17 (0.7 in) D mm |
| Weight: | 98 g (Includes batteries) |

ACCESSORIES

Connecting pin cord

* Design and specifications are subject to change without notice in the course of product improvement.

NIPPON COLUMBIA COMPANY, LTD.

No. 14-14, AKASAKA 4-CHOME, MINATO-KU, TOKYO, JAPAN
Telephone: Tokyo (584) 8111
Cable: NIPPONCOLUMBIA TOKYO Telex: JAPANOLA J22591

DENON

Hi-Fi Component

SAFETY INSTRUCTIONS FOR AUDIO SET

CAUTION

FOLLOW ALL WARNINGS AND INSTRUCTIONS MARKED ON YOUR AUDIO SET AS WELL AS IN THE OPERATING INSTRUCTIONS.

FOR SAFE OPERATION AND FUTURE REFERENCE, PLEASE, READ AND RETAIN THIS SAFETY INSTRUCTION SHEET AND THE OPERATING INSTRUCTIONS

INSTALLATION

1. Operate the set only from a power source as indicated on the rating label (indication) at the back of the set.

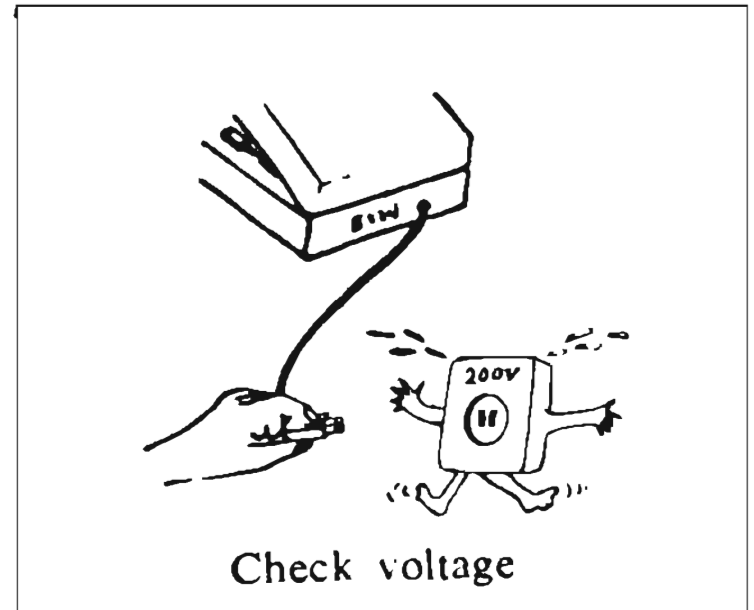

2. Frayed cords and broken plugs may cause a fire or shock hazard. Do not damage the power cord.

§ Do not cut and splice the power cord.

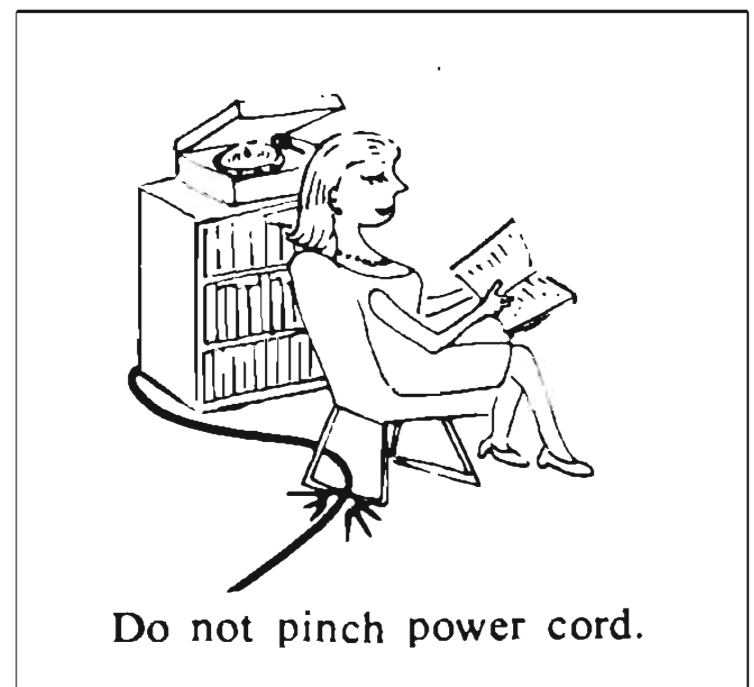

§ When removing the power cord from wall outlet, be sure to unplug by holding the plug attachment and not by pulling the cord. Do not hold the plug by wet hand.

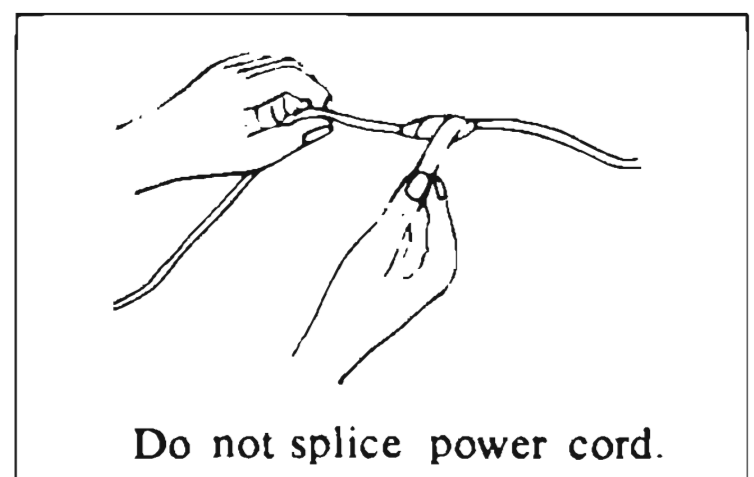

§ Call your service technician for replacement of damaged cords and plugs.

3. Select a place so that the location or position does not interfere with the proper ventilation of the set for releasing heat generated during operation :

SAFETY INSTRUCTIONS

- § Select a flat and level surface allowing enough space for setting up and operation.
- § Never block the bottom ventilation holes placing the set on a bed, sofa, rug, etc.
- § Never place the set in a “built-in” enclosure unless proper ventilation is provided.
- § Never place the set near or over a radiator, heat register or stove.
- § Avoid locations where the set is exposed directly to the sun light.

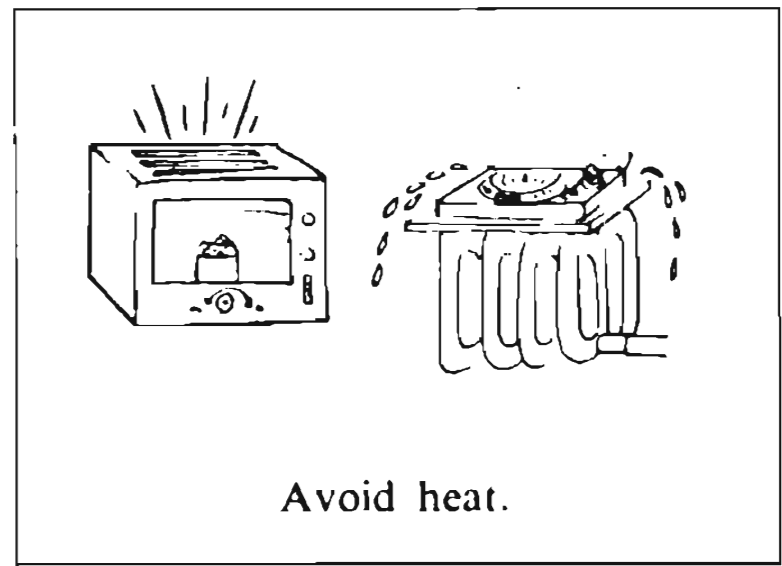

USE

1. Do not expose the set to rain or water (liquid). Do not spill liquid or insert metal objects inside the set. Rain, water or liquid such as cosmetics as well as metal may cause electric shorts which can result in fire or shock hazard. If anything gets inside, unplug the power cord and have a DENON service technician check your set before further use.
2. Never leave your set switched on when leaving the house. For added protection of your audio system during lightning storm or when the set is to be left unused for a

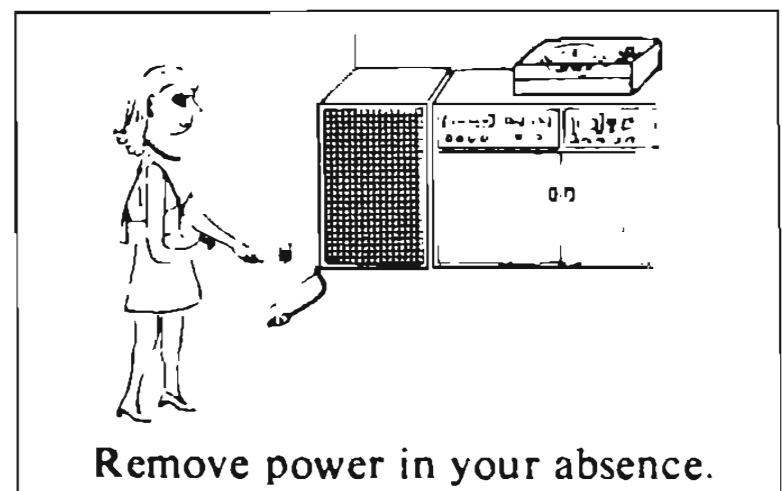

long period of time, be sure to unplug the power cord from the wall outlet.

3. Take care so that the set is not dropped to avoid damaging the cabinet which defeats safeguards or injuring yourself. If the set has been dropped or the cabinet has been damaged, unplug the set and have it checked by a DENON service technician to restore safeguard.

SERVICING

1. The servicing of set must not be attempted by yourself beyond that described in the operating instructions. In case of problems that cannot be settled by referring to your operating instructions, unplug the power cord and contact your DENON dealer. No user-serviceable parts are inside the set. Only qualified service technician can service inside your set.
2. Refer to the operating instructions for maintenance and cleaning.

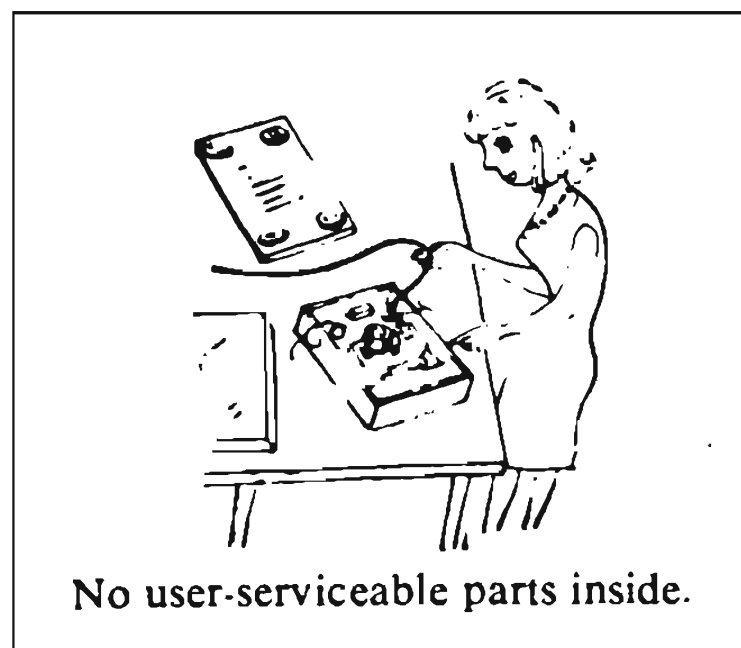
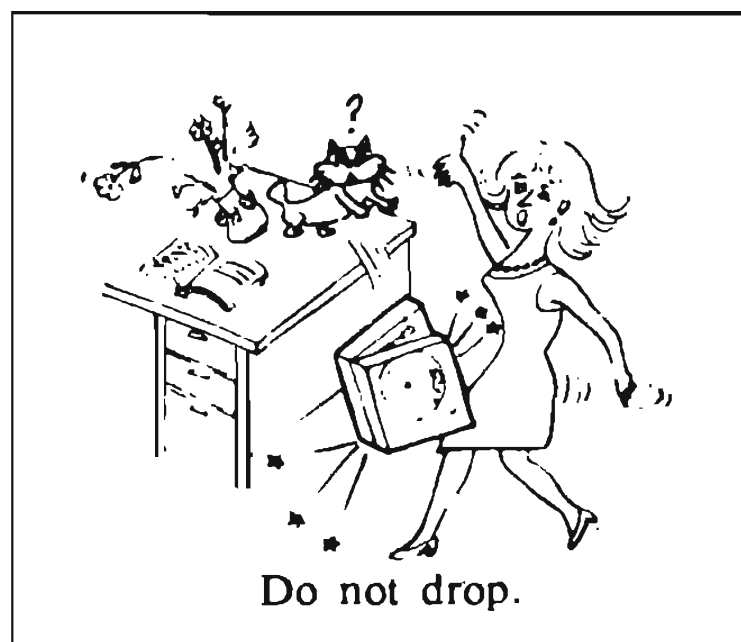

NIPPON COLUMBIA CO., LTD.

No. 14-14 AKASAKA 4-CHOME
MINATO-KU, TOKYO 107 JAPAN

80.9 5118153006
Printed in Japan